

Model: Plockmatic Bookletmaker SR85/TR85		Date: 24-Jan-02	No.: MZP1 015
Modified Article: Installation manual		Prepared by: Berndt Theimer	
From: Plockmatic		Europe/Asia, USA	
Reason for Modification:	<input type="checkbox"/> Parts catalog correction	<input type="checkbox"/> Vendor change	<input type="checkbox"/> To meet standards ()
	<input type="checkbox"/> To facilitate assembly	<input type="checkbox"/> To improve reliability	
	<input type="checkbox"/> Part standardization	<input checked="" type="checkbox"/> Other	

Referring to Modification Bulletin MZP1 013 regarding new Packing Material for the SR85 we had to rewrite the installation manual for the SR85 and TR85.

The new installation manual is to be used:
From Serial number: Europe/Asia: ZP1 28100001
From Serial number: USA: ZP2 28100011

Installation Manual

Bookletmaker SR 85 and Trimmer TR 85

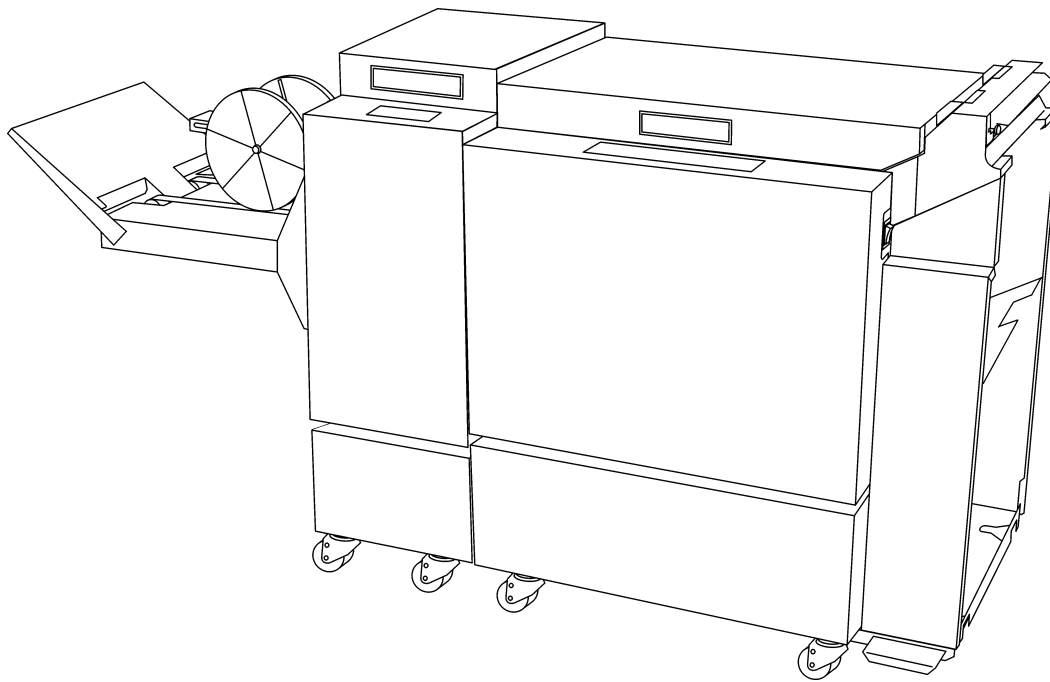

Introduction

This install manual covers the installation of the Booklet maker SR 85 and the Trimmer TR 85.

If you have any comments or remarks, please contact us on one of the following numbers:

Email: support.oem@plockmatic.se

Phone: +46 8 602 50 41
1 800 648 57 73

Fax: +46 8 722 9970

Table of contents

1. Minimum space requirements

Page

1.1 Space requirements 1-1

2. Installing the Bookletmaker

2.1 Unpacking 2-1

2.2 Remove the Panels and Shelf 2-2

2.3 Power requirements 2-3

2.4 Preparing the printer 2-4

2.5 Interface 2-7

2.6 Wiring communication cable 2-8

2.7 Connectors communication cable 2-9

2.8 Adjustments 2-10

3. Installing the Trimmer

3.1 Unpacking 3-1

3.2 Power requirements 3-2

3.3 Attaching the Trimmer to the Bookletmaker 3-3

1. Minimum space requirements

1.1 Space requirements

1. Ensure that the minimum required floor space is available for an installation of the Bookletmaker SR 85 including the Trimmer TR 85 as shown in figure 1.

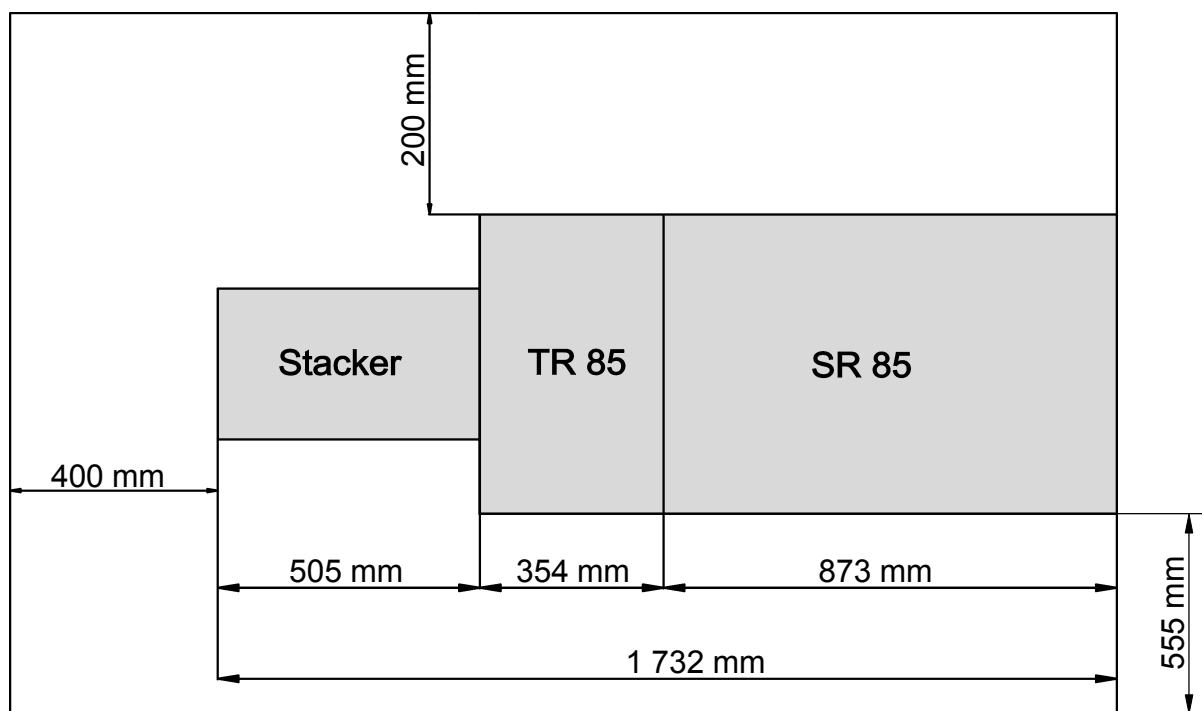

Figure 1

2. Installing the Bookletmaker

2.1 Unpacking

1. Remove all parts from the pallets. Remove the two cardboard handles underneath the Bookletmaker, by pulling them straight out. Slide the SR85 of the pallet.
2. Unpack installation kit.

Box containing:

1. EPROM
2. Exit arm catcher
3. Template
4. Communication cable
5. Powercord
6. Shift tray plate with four 6 x 5.5 mm counter screws.
7. Exit tray plate with four 6 x 5.5 mm screws.
8. Docking assembly for the printer with two screws.
9. Tapping cable

Box

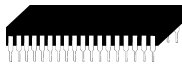

1. EPROM

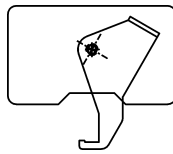

2. Exit arm Catcher

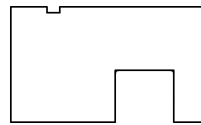

3. Template

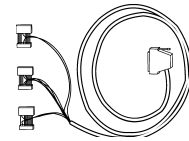

4. Communication Cable

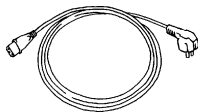

5. Powercord

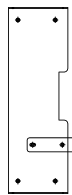

6. Shift tray plate

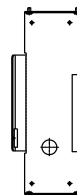

7. Exit tray plate

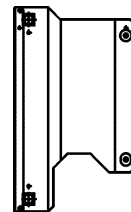

8. Docking assembly for the printer



9. Tapping cable

-
4. Open the Top cover on the Booklet maker and remove the Belt stacker wheel. Install the Belt stacker wheel (1) on the Belt stacker with one 7 mm allen screw. Figure 2.

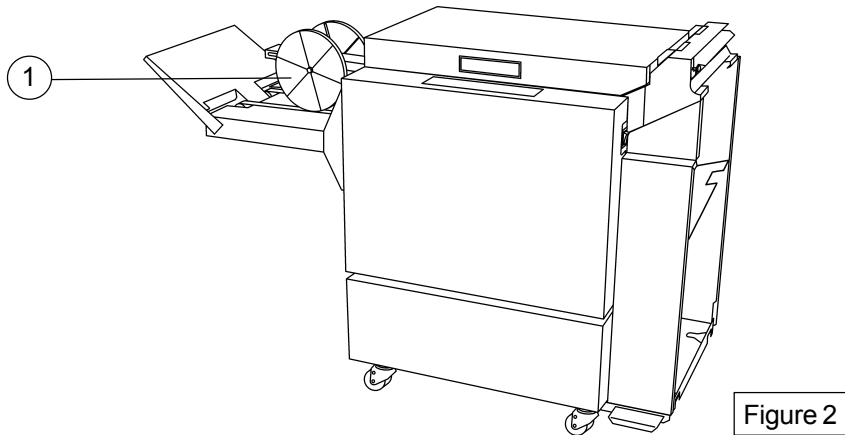

2.2 Remove the Panels and Shelf

1. Remove the Panels and shelf by loosen the four 7 mm screws (1). Figure 3
2. Slide the top of the panels (2) away from the screws. Remove the shelf (3), remove the two panels.

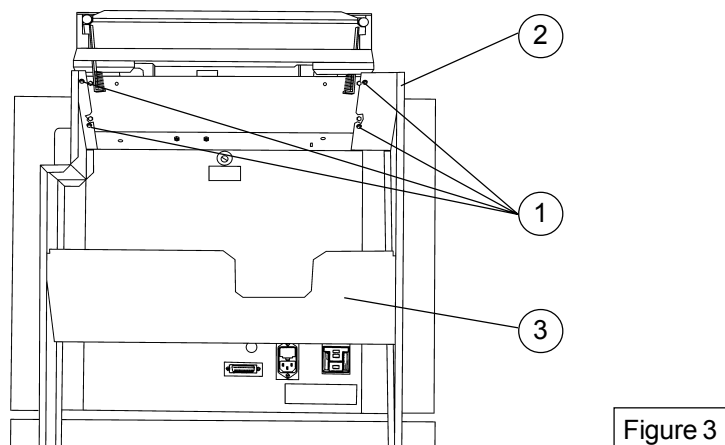

2.3 Power Requirements

Configuration	Nom. Voltage (V)	Bookletmaker Max. Current (A)	With Trimmer Max. Current (A)
Europe	220/230/240	0.5 A	2.0 A
N&S America	105/115/125	1.0 A	4.0 A

1. Remove the Infeed cover (1) by loosen two 8 mm screws, figure 4.

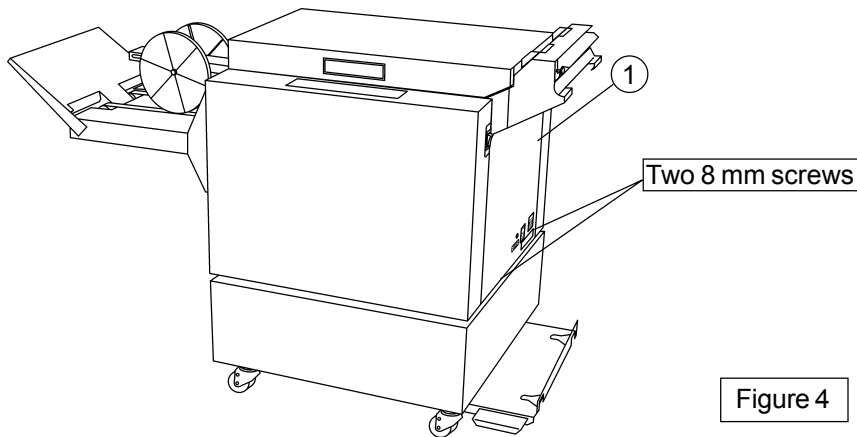

2. Check wall outlet voltage.
3. Check the transformer (2) tapping for the correct configuration, figure 5.
(Machines are tapped for 230V or 115V depending on configuration)

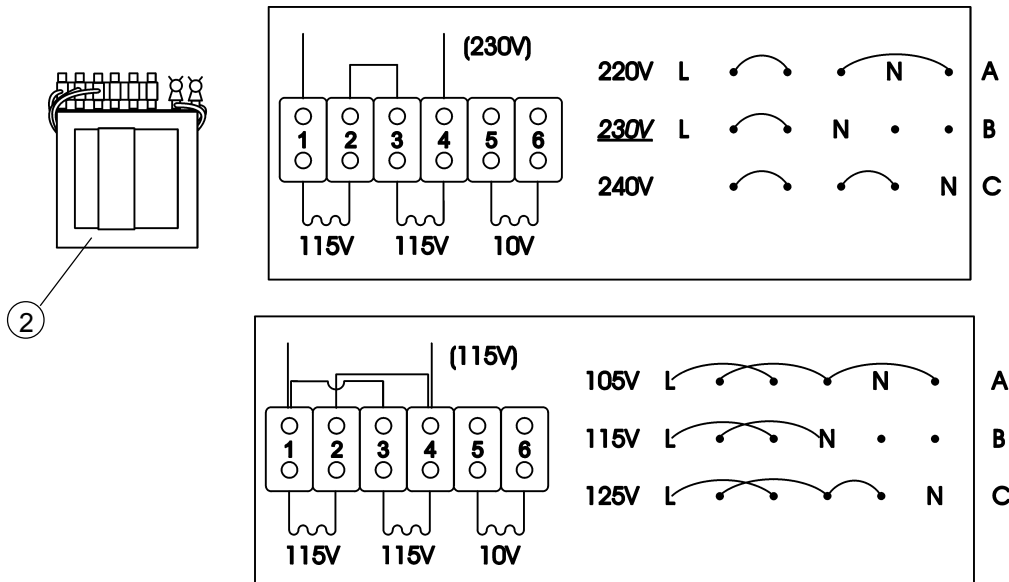

Figure 5

4. Reinstall the Infeed cover. **Do not install the Panels and shelf at this time.**

2.4 Preparing the printer

1. Take the mounting template (1) and hold it to the output on the printer finisher (2). Take the exit arm catcher (3), remove the adhesive from the back of the catcher. Install the catcher on the printer. Lift up the exit paper arm and set onto the catcher (4). Figure 6

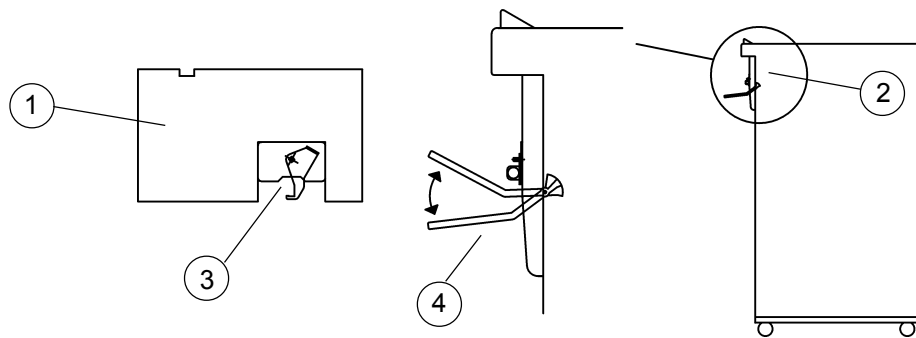
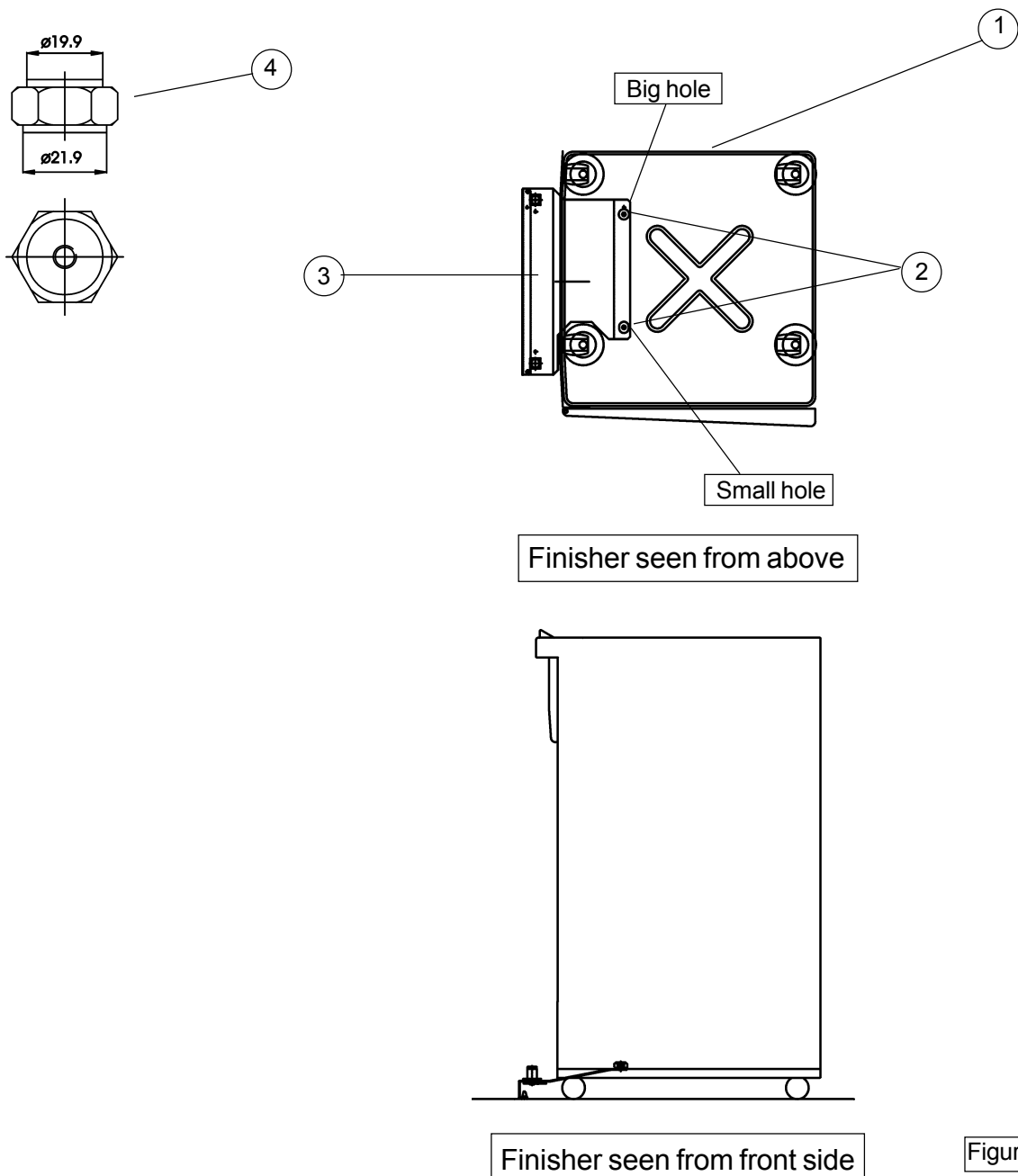

Figure 6

2. Remove the rear cover on the printer finisher (1).
3. Open the printer finisher door and pull out the stapling tray.
4. Remove the two black plastic covers (2) at the bottom of the printer finisher by removing two 5.5 mm screws, figure 7.
5. Take the docking assembly (3) and install it with two positioning screws in the holes who were under the black plastic covers (2). Secure the docking assembly with the two nuts (4). Make sure you turn the nuts correct, one diameter for the small hole and one diameter for the big hole.
There shall be no play in the Docking assembly if mounted correctly.



-
6. Remove the printer exit tray (1) from the printer by removing four 5.5 mm screws, figure 8.

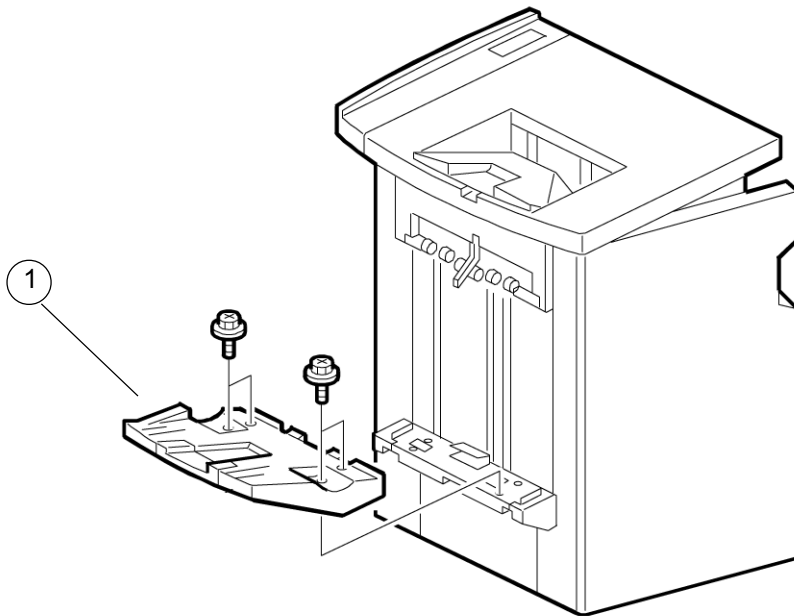

Figure 8

7. Take the printer exit tray (1). Take the exit tray plate (2) and install it with four 5.5 x 6 mm screws (from the installation kit) at the bottom of the exit tray, figure 9.

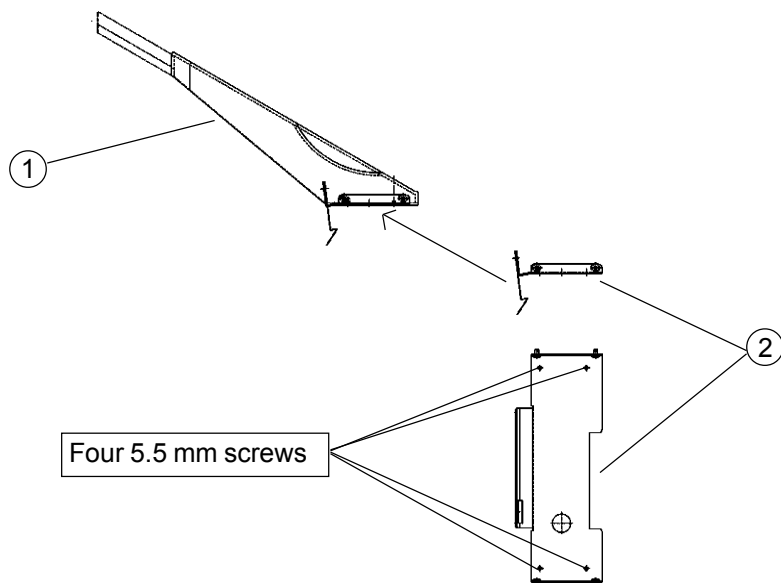
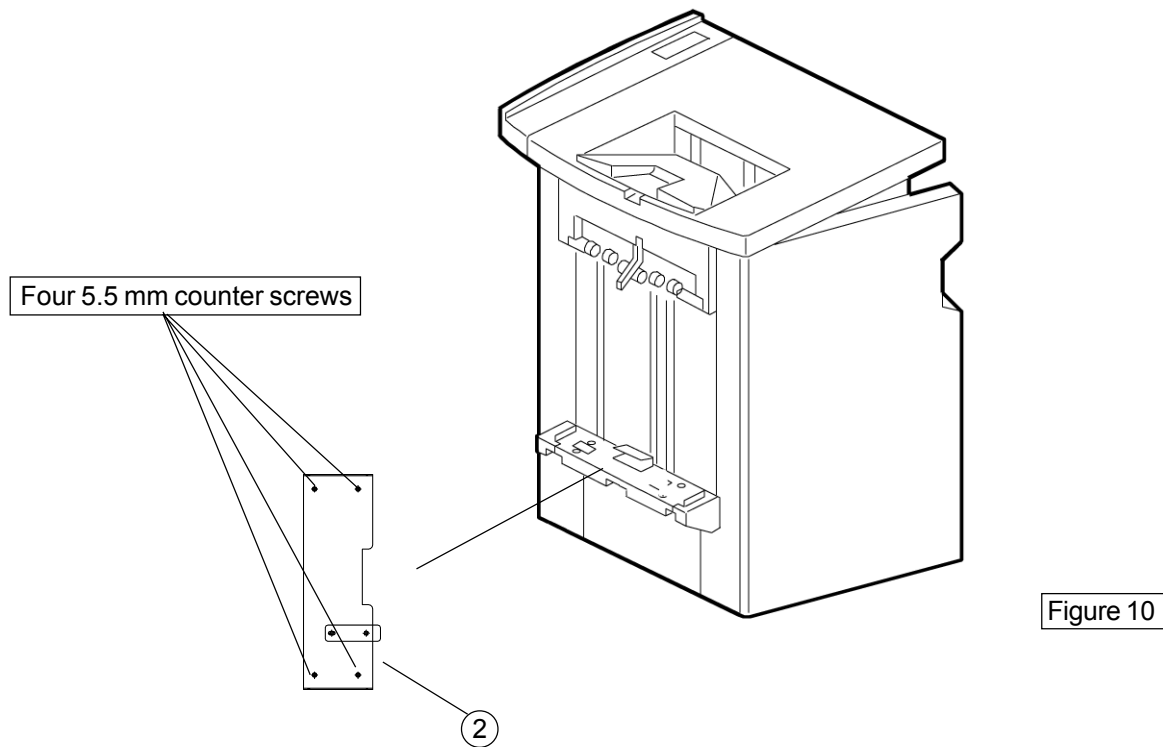

Figure 9

-
8. Take the shift tray plate (2) with the four counter holes and install it on the printer with four 5.5 x 6 mm counter screws (from the installation kit), figure 10.



2.5 Interface

1. Change EPROM on the Main board PCB1 in the printer finisher.
2. Remove the printer finisher connectors CN115, CN120 and CN125 from the Main board PCB1.
3. Take the Communication cable from the installation kit. **Note, make sure you connect the connectors correctly, the yellow wire should always be on top, figure 12.** Connect connectors CN115, CN120 and CN125 on the Main board PCB1.
4. Connect the printer finisher connectors CN115, CN120 and CN125 to the harness.
5. Secure the harness in the finisher with tie raps from the installation kit.

2.6 Wiring communication cable

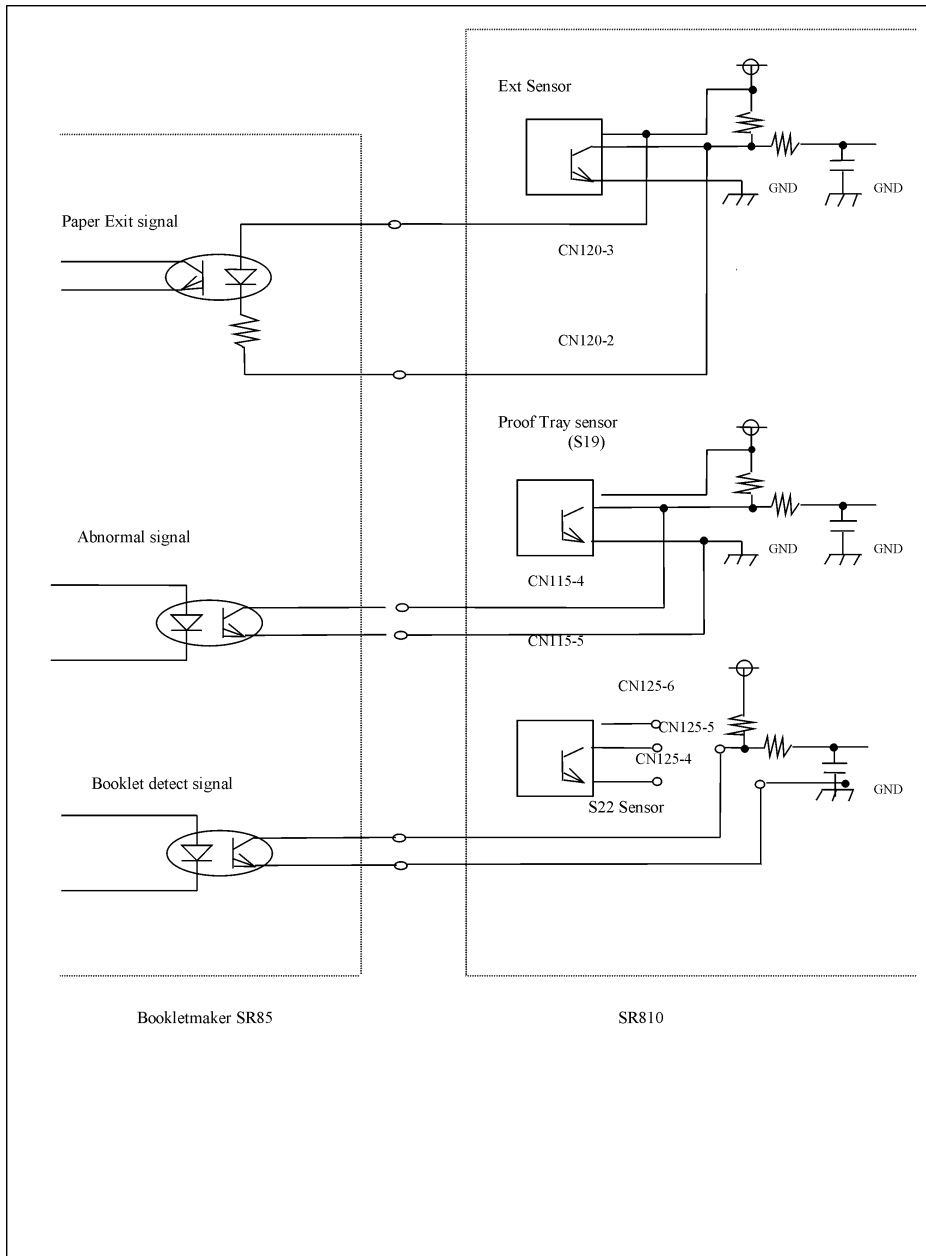
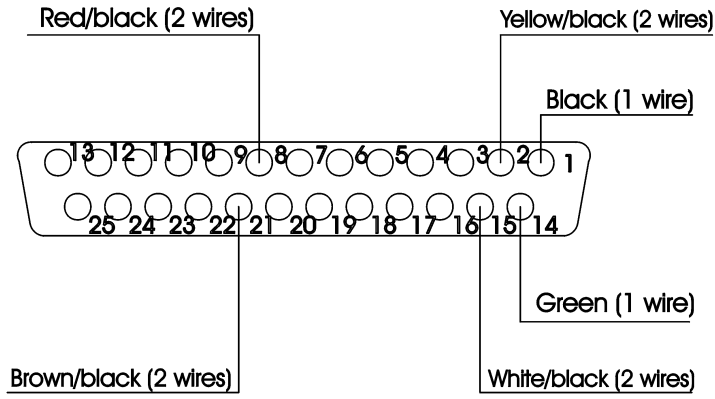

Figure 11

2.7 Connectors communication cable

D-Sub Bookletmaker



Connector CN-115

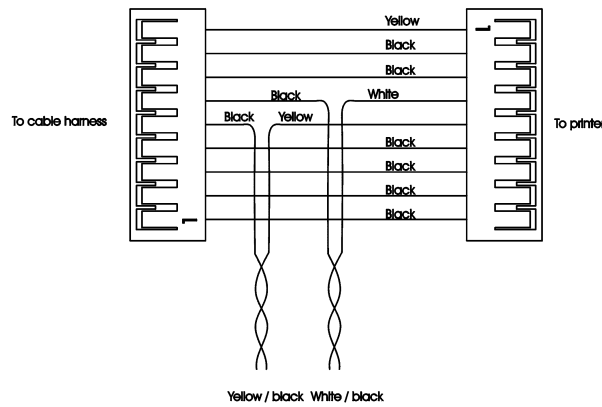

Connector CN-120

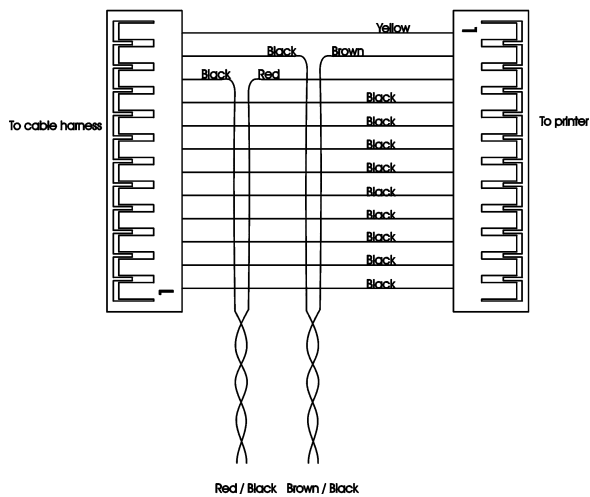

Connector CN-125

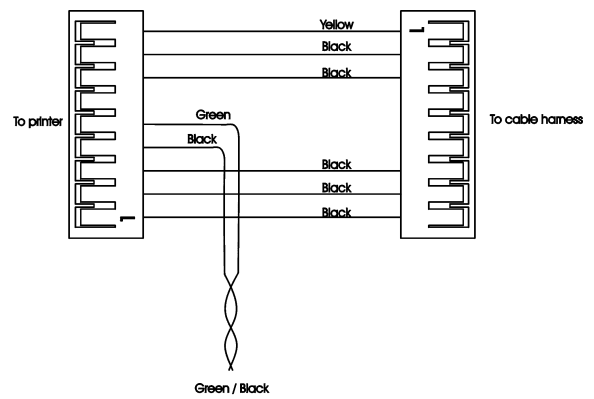

Figure 12

2.8 Adjustments

1. Make sure the exit paper arm is in the upper position (1), figure 13 a. Turn on the printer the shift tray will go down to the lower position. Turn off the printer.
2. Adjust the gap between the infeder assembly and the printer. Adjust by moving the two positioning pins (5) with the caster tool. The caster tool is located behind the front cover in the Bookletmaker. The two black studs on the infeder assembly should just have contact with the printer cover (6), figure 13 a.

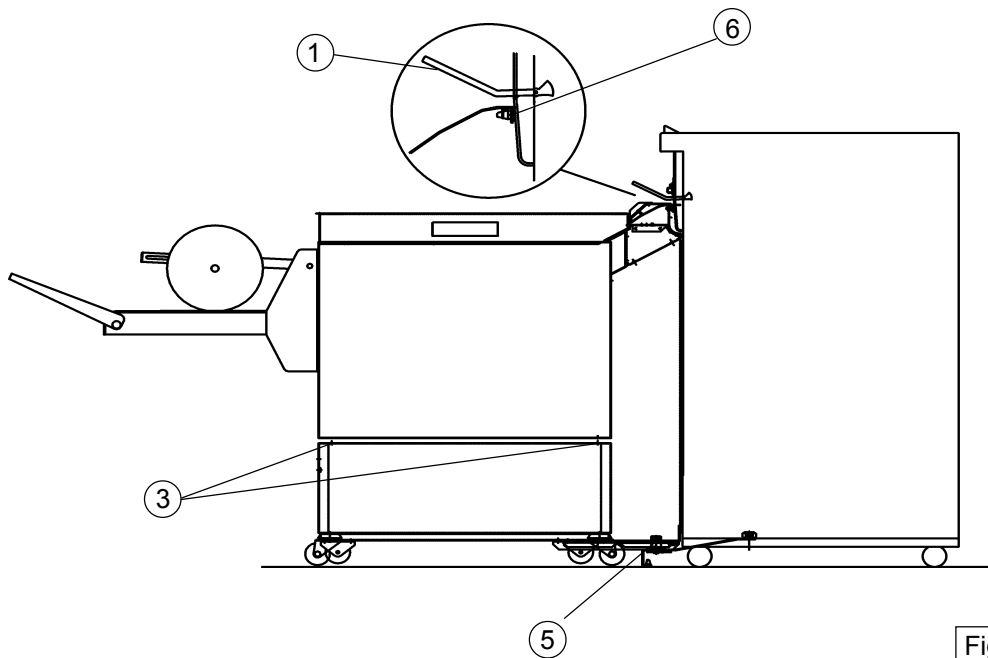

Figure 13 a

3. Adjust the distance between the front of the Bookletmaker infeder and the front of the Printer panel (7). Adjust by moving the two positioning pins (5) with the castor tool. The distance should be 5 - 7 mm, figure 13 b.

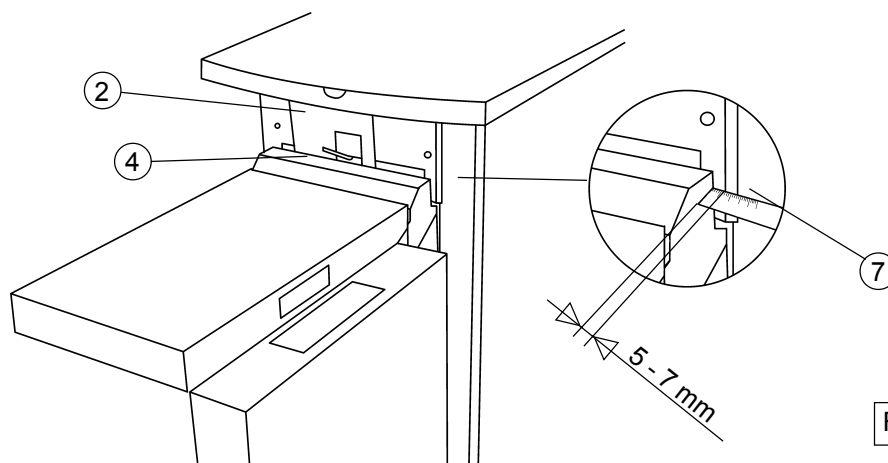

Figure 13 b

-
4. Tighten the two positioning pins.
 5. If installing a Rail. Install it now.
 6. Take the template and hold it to the output on the printer. Adjust the height on the Bookletmaker. Adjust by turning the four nuts on the Bookletmaker with the caster tool (3). Raise or lower the casters to achieve the correct height. The lower edge on the template should be against the stainless plate at the infeed (4), figure 13b.
 7. Undock the Bookletmaker.
 8. Take the front (1) and the rear (2) panels, slide them with the bottom first onto the docking assembly. Put the shelf (3) between the panels, make sure you turn the shelf correct. The cut out should be away from the Booklet maker, not towards. Slide the top of the panels under the screws on the infeed. Tighten the four 7 mm screws. Take the printer exit tray and put it on the shelf, figure 14.

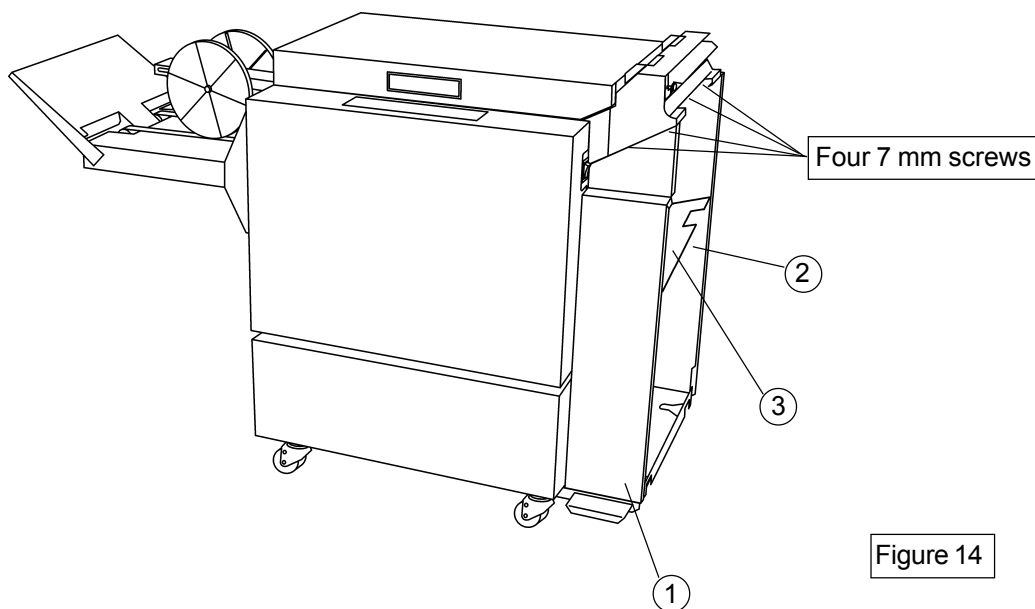

Figure 14

9. Connect the communication cable and the power cord through the hole in the rear panel.
10. Make sure the exit paper arm is in the upper position. Move the Bookletmaker up to the printer and dock it.

-
11. Power on the Bookletmaker.
 12. Set up the Bookletmaker for A4/8.5 x 11" saddle stapling and folding according to the operation manual 4.2. Press the yellow Run / Adjustment button on the Bookletmaker.
 13. Send one A4/8.5 x 11" proof set from the Printer by pressing the "proof button on the printer".
 14. Check for the correct feeding of the paper. The paper should enter in the middle of the infeeder if not perform Adjustment 2.8 on page 2-9.
 15. Open the top cover on the Bookletmaker the set is now in the stapling area, Check length and width, adjust if needed according to the operation manual 4.2.
 16. Close the top cover, press the yellow Run / Adjustment button. Take the book from the stacker and check the fold and the staples, adjust if needed.
 17. Set up the Bookletmaker for A3/11 x 17" saddle stapling and folding according to the operation manual 4.2. Press the yellow Run / Adjustment button on the Bookletmaker.
 18. Send one A3/11 x 17" proof set from the Printer by pressing the "proof button on the printer".
 19. Open the top cover on the Bookletmaker the set is now in the stapling area. Check length and width, adjust if needed according to the operation manual 4.2.
 20. Close the top cover, press the yellow Run / Adjustment button. Take the book from the stacker and check the fold and the staples, adjust if needed.
 21. If installing a Trimmer TR85 go to the Trimmer installation.

3. Installing the Trimmer

3.1 Unpacking

1. Remove all parts from the pallets.
2. Unpack installation kit. Installation kit Box is located in the waste bin on the Trimmer.

- Box 1 containing:
1. Exit guide bracket
 2. Two 8 mm screws with 20 mm washers and two nuts (to secure the trimmer to the Booklet maker)
 3. Plastic distance with one M5x25 screw
 4. Tapping cable

Box 1

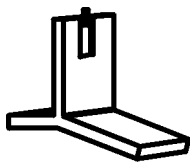

1. Exit guide bracket

2 x

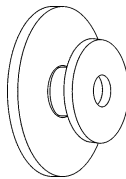

2. Screw with
20 mm washer

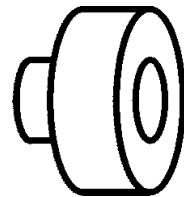

3. Plastic distance



4. Tapping cable

3. Ensure all of the packaging material is removed from the outside of the Trimmer TR85.

- Remove the front cover (1) on the Trimmer by loosen two 8 mm screws, figure 15

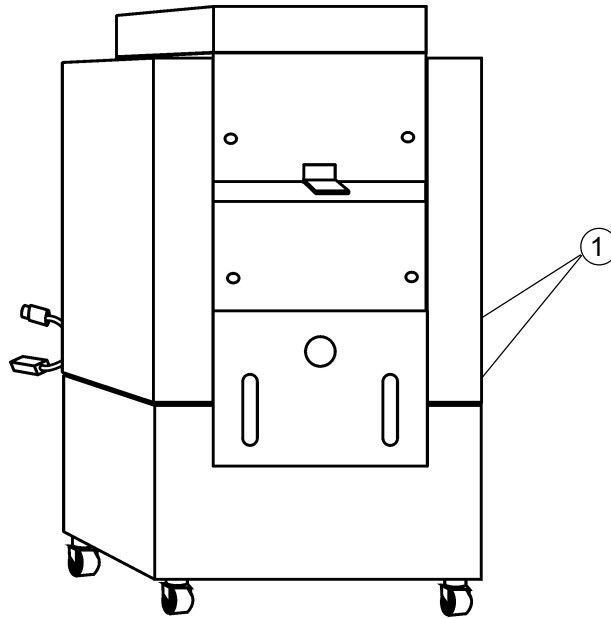

Figure 15

3.2 Power requirements

- Power requirements, see page 2-2
- Check wall outlet voltage.
- Check the transformer (2) tapping for the correct configuration, figure 16. (Machines are tapped for 230V or 115V depending on configuration)
- Reinstall the rear cover.

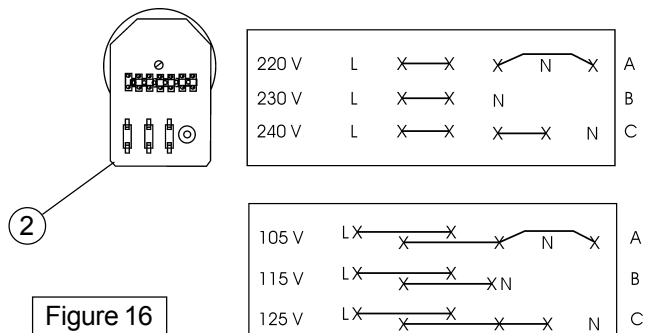

Figure 16

3.3 Attaching the Trimmer to the Bookletmaker

1. Remove the two 8 mm screws (1), figure 17, which secures the Beltstacker.
2. Remove the Beltstacker(10), figure 17.
3. Remove the two black positioning pins for the Beltstacker (2) from the Bookletmaker, figure 17.
4. Take the two screws with the 20 mm washers, install them in the holes where you removed the two black positioning pins (2), figure 17.
5. Remove the old exit guide bracket (3) from the Bookletmaker. Make sure to cut the cable tie on the old exit guide bracket. Replace it with the new one (4), figure 17.
Note: Install it as high as possible!
6. Move the Trimmer up to the Bookletmaker connect the communication cable (6) and the power cord (7), figure 17. Adjust the height on the Trimmer by turning the four nuts (8), figure 17. So that the two black positioning pins fits in the holes on the Trimmer. Lower the Trimmer so that the Trimmer just hangs on the two positioning pins. Make sure the cable not interferes with the fold pocket.
7. Take the allen screw and the plastic distance and attach it to the Trimmer and the Bookletmaker (9), figure 17.
8. Take the stacker and install it on the Trimmer (10), turn the two stacker height brackets (11) a half turn so that the stacker is in the up position, figure 17.
9. Secure the Beltstacker with the screws (1), you removed in step 2, figure 17.

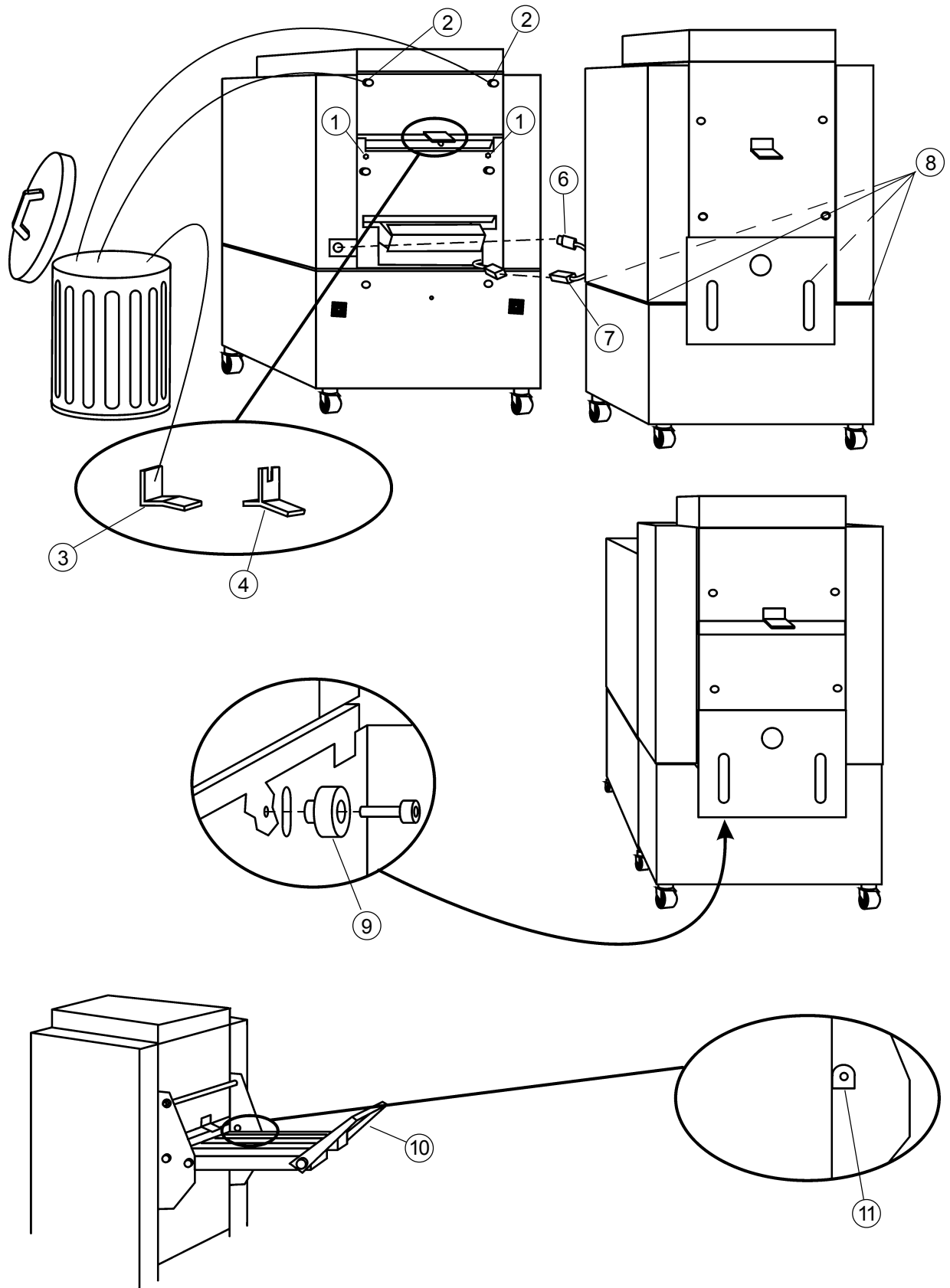

Figure 17